

MODEL 50 TRAMP METAL DETECTOR

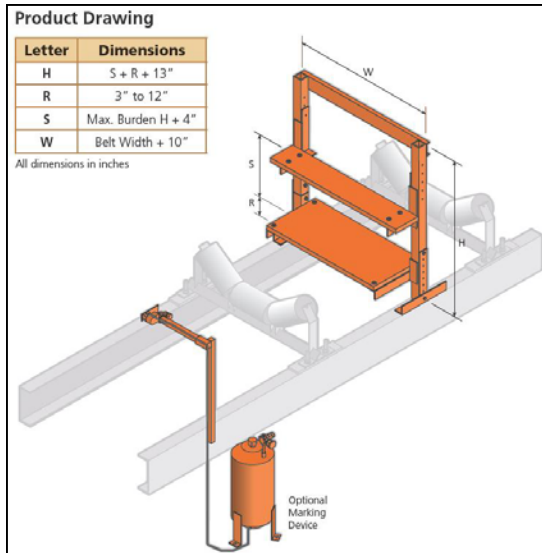

Tough and reliable, the Bulk Pro Systems **Model 50 Tramp Metal Detector** is designed to detect and discriminate between conductive materials and metals, both magnetic and non-magnetic, ferrous and non-ferrous tramp metal. Compatible with fabric or steel core conveyor belts, the Model 50 provides protection to downstream processing equipment by detecting the presence of potentially damaging metal objects.

Considered the "work horse" of Bulk Pro Systems product line, the Model 50 can be tailored for use with non-magnetic conveyed materials or magnetic, highly conductive ores. Some of the industries using and benefiting from the consistent performance of the **Model 50** are: Stone, Sand, Aggregate, Ore, Cement, Ceramics, Coal and Wood.

Features

- **Custom design to fit any conveyor**
- **Easy installation, no need to cut the belt**
- **Swing away antenna**
- **Optional clip detector and marking system**
- **Field replaceable modules**

Benefits

- **Microprocessor Based Electronics**
- **Bar Graph Display**
- **Membrane Keypad and Function LED's**
- **Multilanguage Available**
- **Remote Operation Capability**
- **Three Level Password Protection**
- **Event Log**
- **EEPROM Stored Parameters**
- **Self-Test Circuit with Fault Alarm**
- **Noise Reduction**

SPECIFICATIONS

Input Voltage:	120/220 VAC, 50/60 Hz
Power Required:	
No Output Load	35 Watts
Max Output Load	990 Watts
Output Signals:	
Direct Output	Dry Contacts (SPDT) Rated 3Amps @ 250VAC
Timed Output	Dry Contacts (SPDT) Rated 3Amps @ 250VAC
Fault Output	Dry Contacts (SPDT) Rated 3Amps @ 250VAC
Sensitivity Drift:	Less than 10%
Dust and Humidity:	No Restrictions
Operating Temperature:	-14° F (-10° C) to 120° F (+50° C)
Enclosure Rating:	NEMA-4
Interconnecting Cable:	25' Standard Length
Antenna:	Dual Antenna System
Warranty:	3 Years From Date of Shipment

Examples of Industrial Applications for the Bulk Pro Systems Model 50 Tramp Metal Detector

- **Aggregate** Protects Cone & Roll Crushers
- **Asphalt** Protects Cone Crushers
- **Mining** Protects Cone & Roll Crushers
- **Aluminum** Protects Impact Crushers
- **Coal** Protects Cone & Roll Crushers
- **Cement** Protects Cone & Roll Crushers
- **Wood** Protects Hogs & Impact Crushers
- **Waste Wood** Protects Hogs & Impact Crushers
- **Pressed Wood** Protects Press & Saws
- **Tire Recycling** Protects Knives

The Model 50, when installed on a conveyor system, provides protection to downstream equipment by detecting the presence of potentially damaging metal objects. It is designed to detect all types of tramp metal, magnetic or non-magnetic.

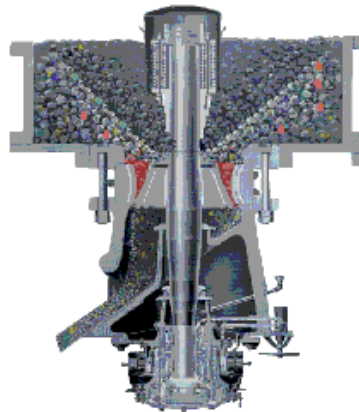

Protect your crushers from tramp metal!

